

## Dynamic modeling of the gas ultracentrifuge using 20-sim

By Ir. Charles A. Mol  
Urenco Nederland B.V.  
Planthofsweg 77, 7601 PJ Almelo, The Netherlands

### Introduction

Urenco is an international company operating Uranium isotope separation facilities in the UK, Germany and The Netherlands (figure 1). The separation is done with gas centrifuges which were developed by Urenco. Several generations of centrifuges have been developed, each one with higher capacity, resulting in machines which are two orders of magnitude better than the first generations.

Such an ultracentrifuge consists of a vacuum recipient with a fast spinning rotor inside. Gas is admitted into the rotor, where it is accelerated until it has nearly the same rotational frequency as the rotor itself. Gas molecules are then subjected to centrifugal forces induced by the centripetal acceleration. Heavy molecules are subjected to larger forces than light molecules and will therefore migrate towards the rotor wall.



Figure 1.

The gas is extracted from the centrifuge by a set of gas extraction scoops; the heavy fraction scoop is located near the rotor wall, whereas the light scoop is more to the centre of the rotor. It can easily be demonstrated that the pressure buildup across the rotor is according to the following formula:

$$p(r) = p(0) \cdot e^{\frac{M \cdot r^2 \cdot \omega^2}{2 \cdot R \cdot T}} \quad (1)$$

where:

- $p(0)$  = pressure in the rotor centre
- $p(r)$  = pressure at radius  $r$
- $M$  = molecular mass
- $\omega$  = angular velocity
- $R$  = universal gas constant
- $T$  = absolute temperature

If the gas consists of two types of molecules with molecular masses of  $M_1$  and  $M_2$ , respectively, the ratios of both partial pressures are:

$$\frac{p_1(r)}{p_2(r)} = \frac{p_1(0)}{p_2(0)} \cdot e^{\frac{(M_1 - M_2) \cdot r^2 \cdot \omega^2}{2 \cdot R \cdot T}} \quad (2)$$

From equation (2) it can easily be seen that the elemental separative effect depends on the absolute difference between both molecular masses  $M_1 - M_2$ . This is essentially different from most other separation processes, where the separative effect is usually dependent of the relative difference  $(M_1 - M_2)/M$ . Separation then becomes increasingly difficult for the heavier isotopes with large  $M$  since the relative mass difference then approaches 0.

Urenco's various types of ultracentrifuges were specifically designed and optimized for the separation of Uranium isotopes with the process gas UF<sub>6</sub> (M<sub>1</sub> = 352, M<sub>2</sub> = 349). It may also be clear that this effect plays no role in the centrifuge where heavy isotopes can be separated as easily as light isotopes (and even better due to secondary effects). In figure 2 a qualitative picture is given of the pressure distributions of a two-component gas mixture inside a fast spinning rotor. The pressure ratios are exaggerated in this figure: in reality the ratio is close to one and the separation of both molecule types requires repeated centrifugation. This elementary separation effect is enhanced by an internal circulation which enables the extraction of the light fraction at one end and the heavy fraction at the other end. The operating principle is shown in figure 3.

Pressure distribution of two gases in ultracentrifuge

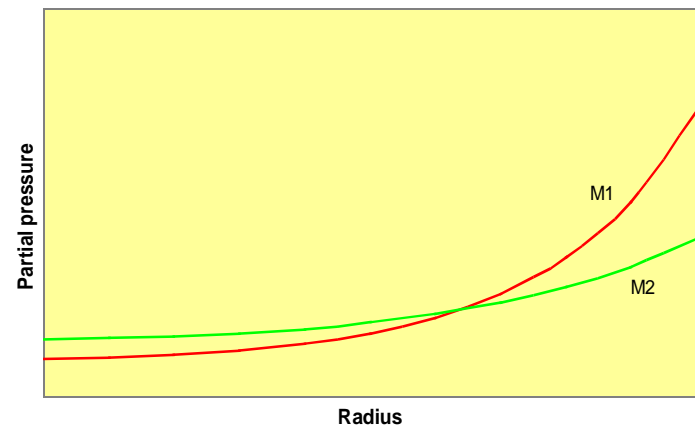

Figure 2.

A single centrifuge does not give enough separation to achieve the required <sup>235</sup>U-isotope concentration. Therefore more machines have to be placed in series. Because each stage generates both light and heavy fractions a network of many centrifuges arises, placed in a series and parallel configuration. This is called a cascade. Large numbers of machines run in such a cascade at constant speed. Therefore, under normal circumstances the operation of a cascade is a very stable process.

### Process dynamics

Why then the interest in its dynamic behaviour? One particular situation may occur which the designer of the separation plant has to take into account: loss of electrical power. When such an event happens the machines will begin to run down. Their UF<sub>6</sub> holdup, however, strongly depends on the angular velocity (eq. 1) and if the gas is not timely removed from a down running machine it will almost certainly crash. The centrifuge recipient is designed to withstand such a crash so that the safety of personnel is not affected nor is the environment, but it would mean a considerable loss of investment: many millions of €'s for just one cascade. Therefore, the plant systems have to provide a UF<sub>6</sub> takeoff facility that is designed to accept the full holdup of all of its cascades.

The rate at which this holdup leaves the machines depends on the moment of inertia of the rotor but also on its friction, which is largely gas friction. The gas friction depends on the UF<sub>6</sub> holdup, which on its turn depends on the behaviour of the cascade control system and the takeoff facility (contingency dump system). A complicated situation for a plant designer since he has to design systems with several, dynamic interactions.

### The Advanced Gas Centrifuge

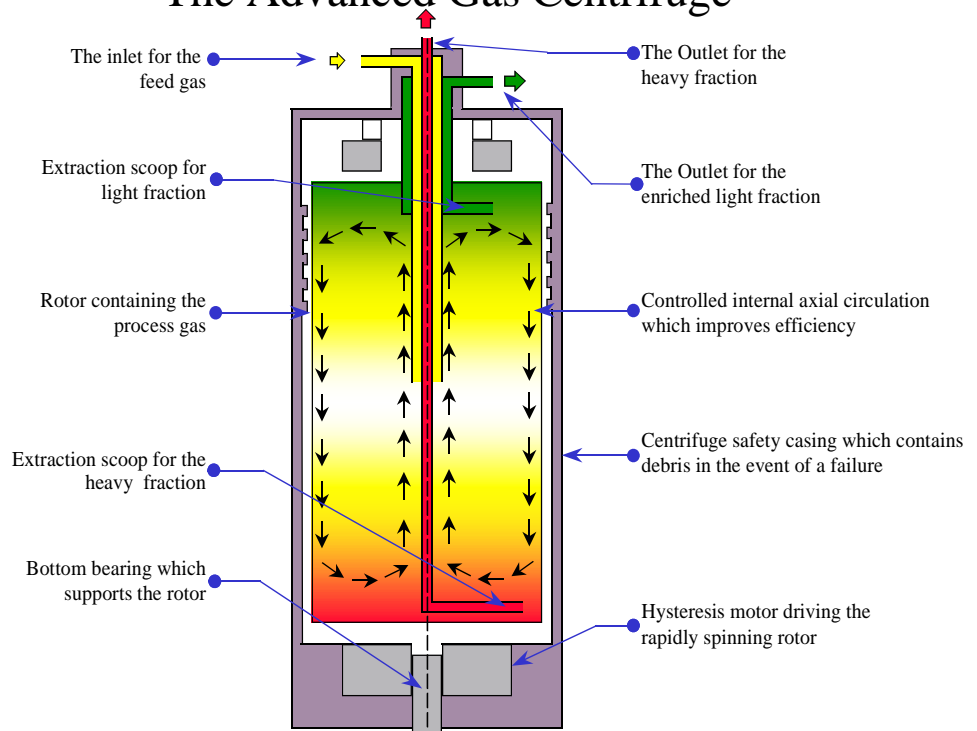

Figure 3.

This is where dynamic modeling of the entire system comes into play. To select a suitable simulation package we have looked at various possibilities. We have found that 20-sim is a professional, fast and user-friendly simulation package with many possibilities allowing to build very complex models. 20-sim has a long standing history with several predecessors, therefore the code has become rather stable. Because of the possibility to model on various levels of detail one keeps a birds eye view on the model instead of getting lost in numerous (necessary) details.

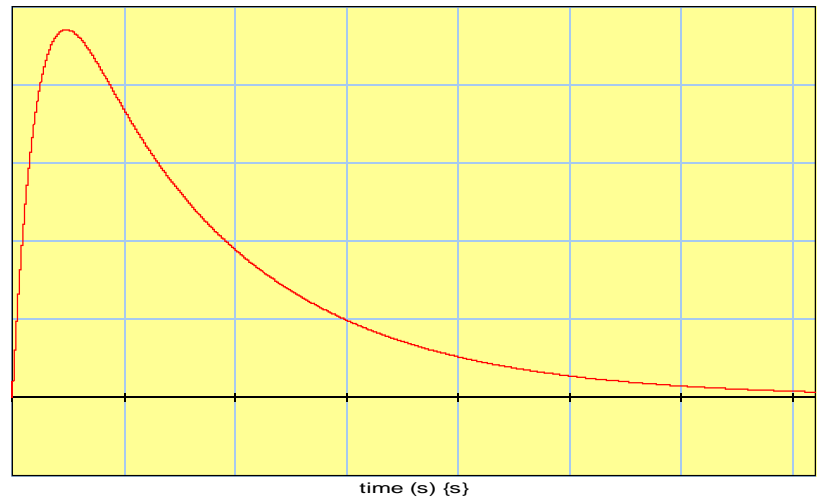

Figure 4. Rundown response

Three different modeling levels are used in this model:

- Cascade control system. On this level the flow and pressure controllers, the cascade piping and the interaction with the contingency dump system are modeled.
- Centrifuges. Contains the internals of the centrifuge.
- Shock wave. Since the gas velocities inside the centrifuge are supersonic shock waves will occur. These are modeled here with the Fanno-Rayleigh equations. This submodel calculates the ratio of the pressures before and behind the shock wave and the Mach number (fig. 5).

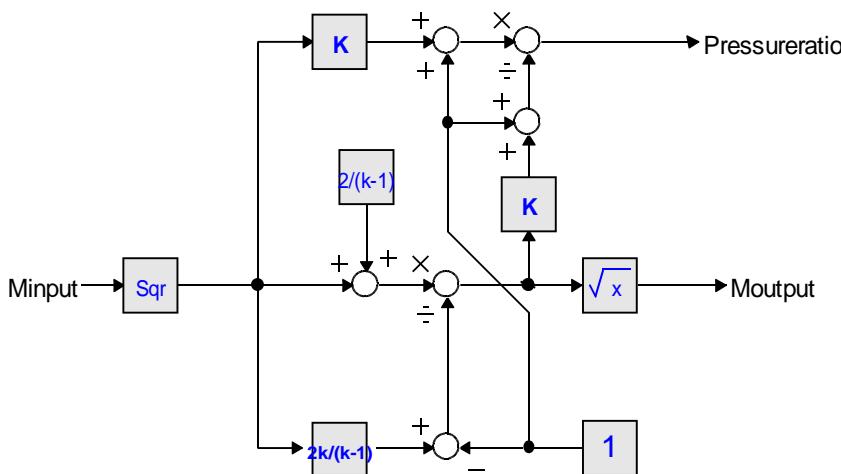

Figure 5. Submodel shock wave

The simulation plot reveals that the flow leaving the cascades in the case of an electrical drive failure or loss of power increases in a relatively short period and then decreases gradually to zero. The peak value thus obtained is considerably higher than the take-off flow during normal operation and therefore it defines the design value of the contingency dump system. Once the model is made and validated various other parameters can also be optimised, e.g. the controller parameters. Also, another problem of control valve limit cycling was solved using this dynamic model.

Links: [www.urengo.com](http://www.urengo.com)  
[www.urengo.nl](http://www.urengo.nl)